

# VERDERFLEX

## Dura 55HF

### Description

Verderflex Dura 55HF (High Flow) Peristaltic Hose Pump is designed for applications such as Metering, Bulk Handling and Transfer duties making it ideal for sludges, slurries, and abrasives.



### Your benefits

- Class leading performance of up to 16.5 m<sup>3</sup>/hr, and pressures of up to 16 bar.
- Minimised downtime and reduced cost of ownership.
- In-situ hose change/simplified spare holding requirement.
- Self-priming (capable of a suction lift of 9.5 mWc), dry running.
- Low shear design ideal for abrasive/solid slurries.
- Sealless, and valveless pumping operation with directly proportional flow stability and repeatability.

### Technical details

Max. flow rate	16.5 m <sup>3</sup> /h	Max. temperature of medium	100 °C <sup>1)</sup>
Max. pump speed	71 RPM	Hose ID	60 mm
Max. discharge pressure	16 bar	Bareshaft Weight	277 kg
Max. suction lift	9.5 mWc	Max. Incompressible Solid Size	6.0 mm
Max. motor power	7.5 kW	Max. Compressible Solid Size	15.0 mm
Weight (301 gearbox, 5.5kW motor)	390kg		

<sup>1)</sup> Materials of construction apply such as hose and lube

### Materials

Description	Materials	Options	Paint Detail
Pump Housing	SG Iron		Green powder coated
Front Cover	Steel		Black powder coated
Window	Plexiglass		
Rotor	SG Iron		Green powder coated
Rotor Shoes	Cast Aluminium	Stainless Steel Material	
Bearing Housing	SG cast iron		Green powder coated
Front/Rear Bearing	Deep Groove Ball Race		
Drive Coupling	SG Iron		Green powder coated
Shaft Seals	Viton		
Mounting Frame	Steel		Black powder coated
Hose Options	Natural Rubber (NR)	Ethylene Propylene Diene Monomer (EPDM)	
Port Flange	CF-8M (316) Stainless Steel Universal slotted design fits with DIN PN16 DN 65, ANSI 150# 2½" & JIS10K	316 Stainless Steel with Polypropylene or P.V.D.F Insert <sup>3)</sup> , DIN11851 Hygienic, DIN32676 Tri-clamp	
Lubricant Options	Verderlube - Glycerine based lubricant <sup>4)</sup> Verdersil - Silicone based lubricant <sup>5)</sup>		

<sup>3)</sup> Temperature Limit for PP insert is 40°C and for PVDF insert is 80°C. <sup>4)</sup> Temperature Limit for Verderlube is 50°C. <sup>5)</sup> Suitable for application above 50°C, but subject to maximum temperature limit of the hose and applications involving strong oxidising agents and nitrogenous compounds.

# VERDERFLEX

## Dura 55HF

### Options and accessories

- Hose burst kit
- Lubricant level gauge (optional).
- ATEX



### Dimensions

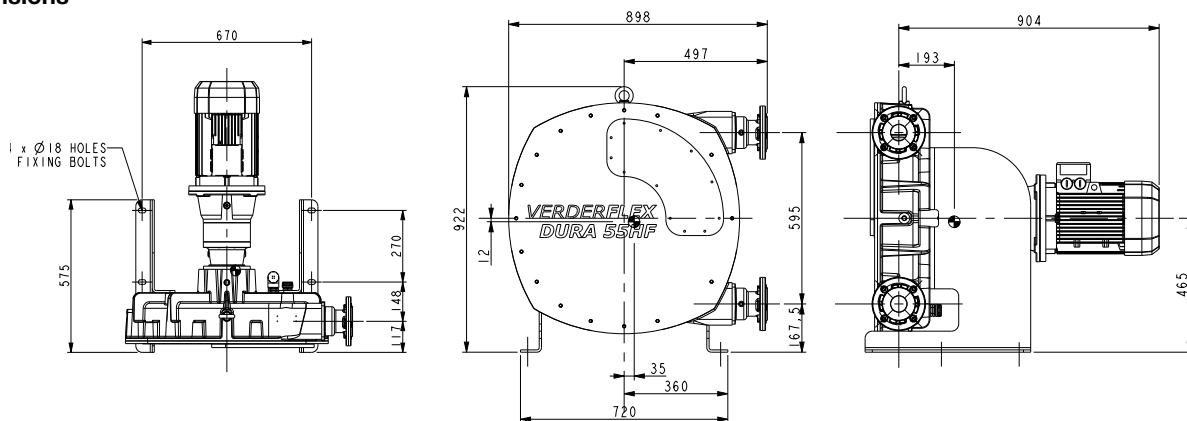

All dimensions are in mm.  
All dimensions and weights are for guidance only.

### Performance curve

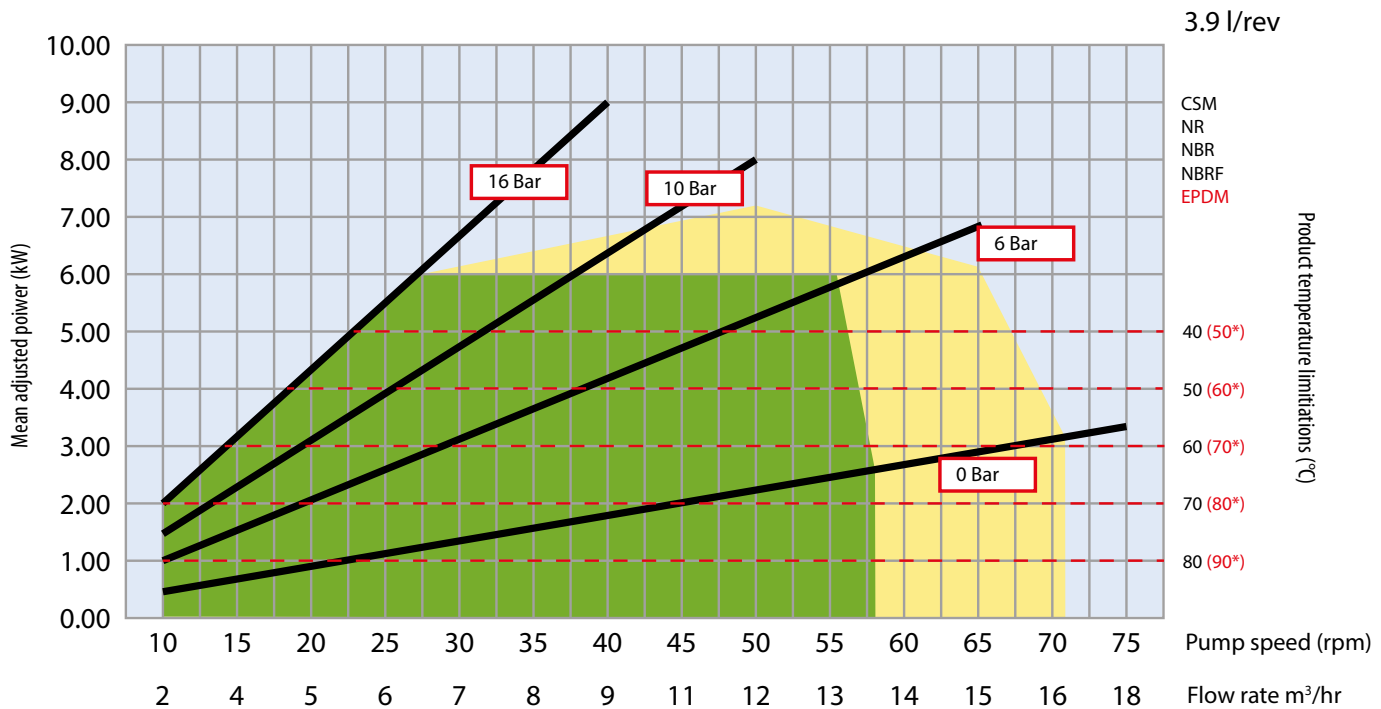

Continuous use  Intermittent use   
\*Shimmable max. 1 hour running min. 1 hour stopped

\*For the number of shims required, please refer to the manual.

Flows are typical and were measured with water at 20°C with 1 metre suction lift or discharge pressure. Actual flows will vary according to suction conditions, discharge pressure and normal component production tolerances.

# VERDERFLEX

## Dura 55HF

**Preferred pump options for 50Hz motor fitted with planetary gearbox, suitable for inverter duty**

Flow l/hr	Pump speed RPM	Installed motor power kW	Maximum pressure (Bar)
2,574	11	3	16
3,276	14	4	16
4,446	19	5.5	16
5,148	22	4	10
6,552	28	5.5	10
8,892	38	7.5	10
10,296	44	5.5	6
11,232	48	7.5	6

Other flow rates and discharge pressures are available on request.



Dura\_55HF - Datasheet\_LEU (Rev00)

### Trademarks

VERDERFLEX® is a registered trademark of Verder Liquids B.V. No permission is granted to use any Verder, trademarks or trade names included in this document without the prior written agreement of Verder Liquids B.V. Tri-clamp® is a registered trademark of Alfa Laval Corporate AB. Hypalon® is a registered trademark of RSCC Wire & Cable LLC.

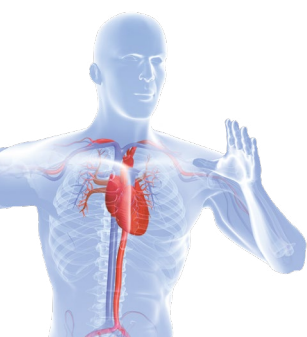

*Find your local supplier at [www.verderliquids.com](http://www.verderliquids.com)*

*For construction, installation and floor mounting drawings please contact your local authorised Verderflex® distributor.*

**VERDER**  
passion for pumps